

FALCON 80

VACUUM PACKAGING MACHINE



FEATURES

- Standard with 2 seal bars: 1 x 760 (front), 1x 510 mm (right)
- Other seal bar configurations available for free (front-back, left-right)
- Standard double seal (two wires). Optional without extra costs: Cut-off/Wide seal
- Silicon holders easily removable for cleaning and maintenance purposes
- Pump capacity: 100 m³/h Busch vacuum pump
- Pump maintenance and cleaning program
- Machine cycle: 15-40 sec
- Standard Digital control with 10 program memory and Time control
- Comes with insert plates for a faster cycle and product adjustment
- Stainless steel frame
- Aluminium chamber and lid with sight glass

OPTIONS

- 1-2 Cut-off seal
- Bi-active seal
- 3 seal bars (left-front-right)
- Soft Air
- Sensor control, Advanced Control System (ACS)
- Liquid control
- Gas flush

ACCESSORIES

- Zebra ZD410 thermal label printer (only in combination with ACS)
- Inclined insert plate (for packing liquids)
- Service kit for standard maintenance

DESCRIPTION

The robust Falcon 80 vacuum packaging machine with stainless steel frame is standard equipped with a Busch vacuum pump, an aluminium lid and vacuum chamber and 2 seal bars. This floor model complies with CE standards.



Henkelman offers standard 3 year warranty

SEAL BAR CONFIGURATION

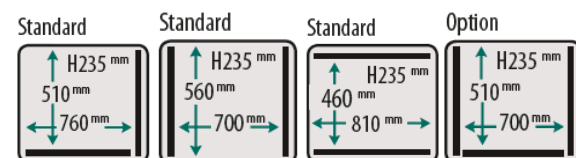

VACUUM PACKAGING MACHINE FALCON 80 – SPECS

VACUUM PACKAGING MACHINE FALCON 80 – SPEC SHEET

DIMENSIONS

In mm

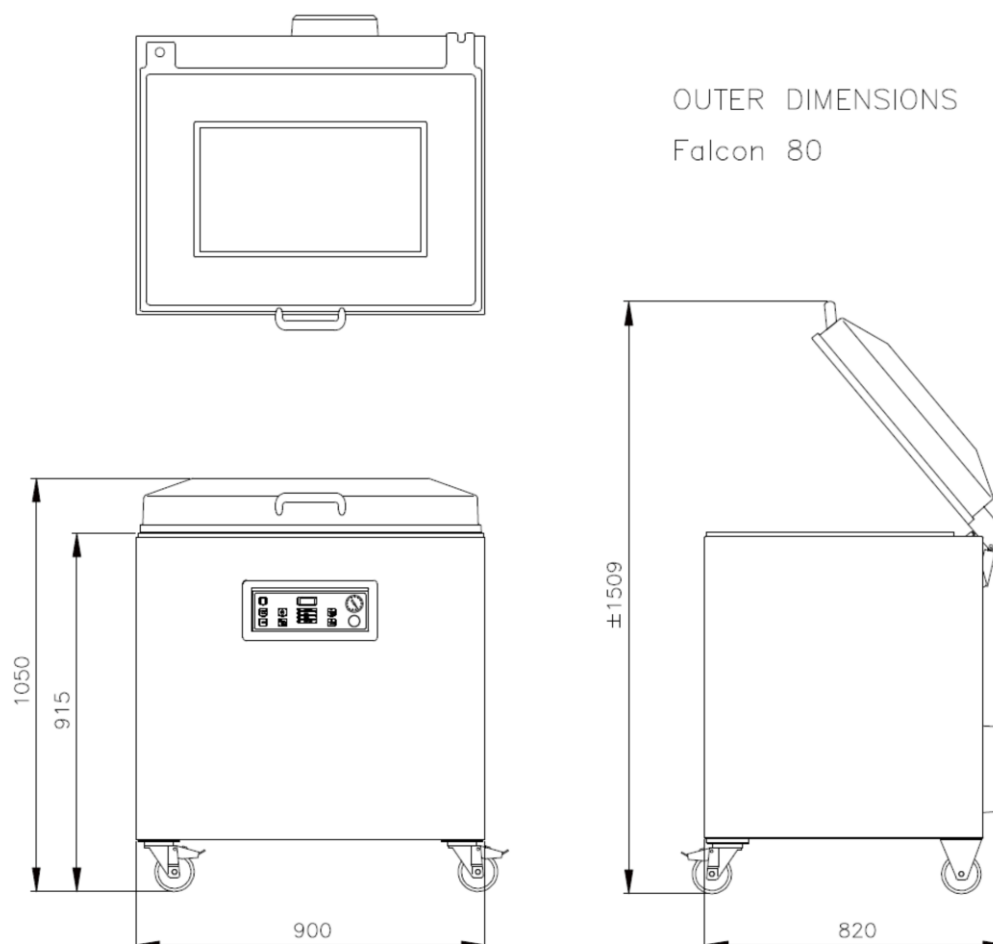

Model	Dimensions (mm)		Voltage*	Pump capacity (m ³ /h)	Power (kW)	Weight (kg)
	Chamber (usable space) L x W x H	Machine L x W x H				
Falcon 80	510 x 760 x 235	820 x 900 x 1050	400V-3-50	100	3,0 – 5,0	227

* Other voltages available



HENKELMAN BV
Titaniumlaan 10
5221 CK 's-Hertogenbosch
The Netherlands

Sales support
P +31 73 621 36 71
E info@henkelman.com
Service/technical support
P +31 73 621 36 71
E service@henkelman.com